



JenLas[®] D2.mini 5/8 W (Preliminary) Diode-Pumped Thin-Disk Laser



Features:

- Minimal dimensions
- Low heat dissipation
- OEM design
- Accessories available

Advantages:

- Ideal for small devices
- Low cooling requirements
- Designed for integration
- Complexity reduction

Applications:

- Dermatology
- Show & Entertainment
- Science
- Pumping of Ti:Sa
- Marking

JenLas® D2.mini 5/8 W (Preliminary)

Diode-Pumped Thin-Disk Laser

Specifications

Parameters	
Laser	frequency-doubled thin-disk laser, diode-pumped
Laser class	4 (according to EN 60825-1)
Wavelength	532 nm ± 1 nm
Ambient temperature	+ 5 °C ... + 40 °C

cw operation	
Output power	5.0 W or 8.0 W
Power stability (rms)	< 2 % (depending on master device)
Beam quality M ²	typ. < 5
Beam diameter	< 2 mm
Divergency	< 2 mrad (half angle)
Pulse duration, switchable via diode laser current	~ 1 ms to cw (amplitude modulation up to 50 kHz possible)

Electrical specifications	
Electrical input data	2 V, < 40 Amp @ laser diode for 8 W
Input power	< 80 VA

Mechanical specifications	
Dimensions (W x H x L)	105.7 mm x 67 mm x 33.5 mm
Weight	~ 0.5 kg

For the operation of the laser, a suitable power supply must be used that complies with the regulations relevant to the respective application. Please contact us for further technical details.

Laser head

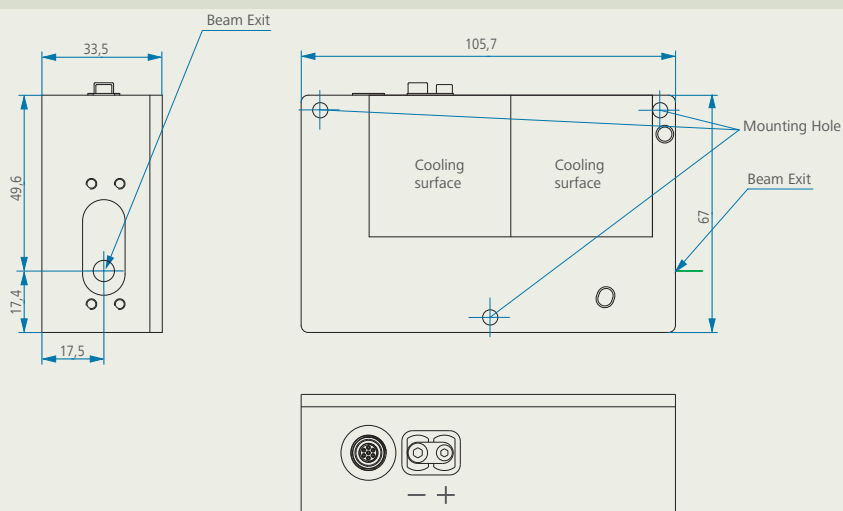

It is our policy to constantly improve the design and specifications. Accordingly, the details represented herein cannot be regarded as final and binding.



JENOPTIK | Lasers & Material Processing

JENOPTIK Laser GmbH

Goeschwitzer Strasse 29 | 07745 Jena | Germany

Phone: +49 3641 65-3053 | Fax: +49 3641 65-4011

E-mail: sales-laser.lm@jenoptik.com | www.jenoptik.com/solidstatelasers

