



575 Series Pulse Generator Operating Manual

Berkeley Nucleonics Corp.
2955 Kerner Blvd.
San Rafael, CA 94901
(415) 453-9955 phone
(415) 453-9956 fax
www.berkeleynucleonics.com

June 2007
Bootrom V 1.02
Firmware V 1.20

Contents

1 Introduction	1
Technical Support	2
Warranty	2
Package Contents	2
Safety Issues	3
2 Front Panel Overview	5
575 Front Panels	6
Display Layout and Indicators	6
Description of Front-Panel Area	6
Keypads	6
Rotary Adjustment Knob	7
Second Level Menus	7
3 Pulse Concepts & Pulse Generator Operation	9
Counter Architecture Overview	10
System Timer Functions	10
Channel Timer Functions	11
Output Multiplexer	11
Dependent & Independent Timing Events	11
Navigating the 575 Front Panel	11
Selecting Menus	11
Selecting Menu Items	12
Numeric Input Mode	12
Entering Non-Numeric Parameters	12
Alphanumeric Input Mode	12
Enabling System Output	13
Enable/Disable Channel Output	13
Rearming the Channel Timers	13
Setting Pulse Timing Parameters	13
Setting Pulse Output Parameters	13
Using the Output Multiplexer	14
Setting System Internal Rate	14
4 575 Menus	15
575 Menu Structure	16
System Mode Menu	18
Setting System Mode of Operation	18
Channel Menus	18
Enabling Channel Output	19
Setting the Channel Timing Parameters	19
Setting Pulse Output Configuration	19
Setting Pulse Mode of Operation	19

Delaying the Start of Channel Output	19
Configuring the Channel Multiplexer	19
Advanced Channel Menus.....	20
Setting the Sync Source	20
Setting Channel Gate Control	20
Gate Menu	21
Enabling System Gate	21
Trig Menu.....	21
Enabling System Trigger	21
Rate Menu	21
Setting the Clock Source and Internal Rate	21
Setting the Output Reference	21
System Menu	22
Setting System Communication Parameters	22
Setting Keypad Parameters	22
Setting the Auto Start Mode	22
Setting the Display Decimal Mark	22
Setting the Display Brightness.....	22
Store Menu.....	23
Storing a Configuration	23
Recall Menu	23
Recalling System Configurations	23
5 Operating the 575.....	25
Quick Start - Normal Internal Rate Generator Operation.....	26
Quick Start - Normal External Trigger Operation	26
System Timer Overview	27
To Use Continuous Mode	27
To Use Single Shot Mode	27
To Use System Burst Mode Function	28
To Use System Duty Cycle Function	28
Channel Timer Overview.....	28
To Use Normal Mode Function	28
To Use Channel Single Shot Function	29
To Use Channel Burst Mode Function	29
To Use the Channel Duty Cycle Function	29
To Use the Channel Gating Function	30
External Input Overview.....	30
To Generate a Pulse on Every Trigger Input	30
To Generate a Burst of Pulses on Every Trigger Input	31
To Start a Continuous Stream of Pulses Using the External Trigger	31
To use the External Gate to Control the System	32
6 Programming the 575.....	33
Personal Computer to Pulse Generator Communication	34
RS232 Interface Overview.....	34
USB Interface Overview	34

GPIB Interface Overview	35
Ethernet Interface Overview	36
Programming Command Types and Format	36
Line Termination.....	36
IEEE 488.2 Common Command Format.....	37
SCPI Command Keywords	37
SCPI Command Format	38
SCPI Format.....	38
SCPI Keyword Separator	38
SCPI Optional Keywords.....	38
SCPI Specific and Implied Channel	38
SCPI Parameter Types	39
Error Codes.....	39
Programming Examples	39
575 SCPI Command Summary	40
575 SCPI Command Summary	41
575 SCPI Command Summary	42
575 SCPI Command Summary	43
IEEE 488.2 Common Commands	44
Appendix	45
Appendix A - 575 Specifications	46
Appendix B - Safety Symbols.....	49
Appendix C - 35V Output Module	53
Appendix D - Dual Trigger Input	54
Appendix E - Impedance Matching Outputs	56
Appendix F - Com	57
Appendix G - Ethernet Connectivity	59

This document was created with Win2PDF available at <http://www.daneprairie.com>.
The unregistered version of Win2PDF is for evaluation or non-commercial use only.

Introduction

Introduction

This manual is a reference designed to familiarize you with the Berkeley Nucleonics 575 series pulse generator and is arranged so that you can easily find the information you're looking for. Generally, each topic has its own section and no section assumes that you've read anything else in the manual.

Technical Support

For questions or comments about operating the 575 -- our technical staff can be reached via one of the following methods:

- Phone - (415) 453-9955
- Fax - (415) 453-9956
- Internet - www.berkeleynucleonics.com

Warranty

In addition to a 30-day money back guarantee, the 575 has a one-year limited warranty from the date of delivery. This warranty covers defects in materials and workmanship. Berkeley Nucleonics will repair or replace any defective unit. Contact us for information on obtaining warranty service.

Package Contents

The box you receive should contain the following:

- 575 Pulse Generator
- AC Power Cord
- User's Manual on Disc

Contact Berkeley Nucleonics (415) 453-9955 if any parts are missing.

Safety Issues

Normal use of test equipment presents a certain amount of danger from electrical shock because testing must be performed where exposed voltage is present.

An electrical shock causing 10 milliamps of current to pass through the heart will stop most human heartbeats. Voltage as low as 35 VDC or RMS AC should be considered dangerous and hazardous since it can produce a lethal current under certain conditions. Higher voltages pose an even greater threat because such voltage can easily produce a lethal current. Your normal work habits should include all accepted practices that will prevent contact with exposed high voltage, and steer current away from your heart in case of accidental contact with a high voltage. You will significantly reduce the risk factor if you know and observe the following safety precautions:

- If possible, familiarize yourself with the equipment being tested and the location of its high-voltage points. However, remember that high voltage may appear at unexpected points in defective equipment.
- Do not expose high voltage needlessly. Remove housing and covers only when necessary. Turn off equipment while making test connections in high-voltage circuits. Discharge high-voltage capacitors after shutting down power.
- When testing AC powered equipment, remember that AC line voltage is usually present on power input circuits, such as the on-off switch, fuses, power transformer, etc.
- Use an insulated floor material or a large, insulated floor mat to stand on, and an insulated work surface on which to place equipment. Make certain such surfaces are not damp or wet.
- Use the time-proven “one hand in the pocket” technique while handling an instrument probe. Be particularly careful to avoid contact with metal objects that could provide a good ground return path.
- Never work alone. Someone should always be nearby to render aid if necessary. Training in CPR first aid is highly recommended.

Front Panel Overview

Front Panel Overview

575 Front Panels

Display Layout and Indicators

A 4 line x 20 character vacuum fluorescent display module displays parameters and status information. The status information is located in the upper-left corner of the display, between the two brackets. There are three enunciators:

- Vertical Arrow Indicates there are additional pages to the current menu.
- Blinking Light Indicates the unit is actively generating pulses, or armed and waiting for an external trigger.
- Musical Note Indicates the function key has been pressed.

The upper-right side of the display contains the title of the currently displayed menu. The rest of the display is used for system parameters. The display brightness may be adjusted, allowing the instrument to be used under various lighting conditions.

Description of Front-Panel Area

Keypads

Three keypad areas provide fast access to various menus and easy editing of system parameters.

- Channel Keypad Provides one touch access to the menus for setting up the channel parameters. Pressing the appropriate letter will display the parameters for the corresponding channel.
- Arrow Keypad The up/down arrows are used to increment/decrement the current parameter (indicated by the blinking cursor). The position of the cursor controls the step size for each increment. The right/left arrow moves the cursor to different positions within the current parameter. The **NEXT** key selects the next parameter in the currently displayed menu. The yellow **FUNC** key allows the keys to select the yellow functions.
- Numeric Keypad Allows numbers and alphanumeric values to be entered. When entering alphanumeric values, pressing a key will display the first letter shown on the key. Repeated key presses will toggle through all the letters, both upper and lower case, shown on the keycap. To enter two letters which appear on the same keycap,

select the first character, then use the right arrow to shift to the next position and enter the next letter. When data entry is complete the **ENTER** key must be pressed.

Rotary Adjustment Knob

An alternate to the Arrow Keypad, the Rotary Adjustment Knob may be used to adjust the current parameter. The step size is controlled by the position of the cursor, however turning the knob faster will increase the step size. Pushing the knob will perform functions similar to the **NEXT** key and switch to the next parameter in the currently displayed menu.

Second Level Menus (Function Key)

The second level menus (indicated in yellow above certain keys) are accessed through the use of the yellow **FUNC** key. Pressing the **FUNC** key once and then pressing the desired menu key will display the specified second level menu. Pressing the **FUNC** key twice in succession will put the unit into "Function Lock" mode, where the second level menus can be accessed without repeatedly pressing the **FUNC** key. Pressing the **FUNC** key a third time will exit "Function Lock" mode.

**Pulse Concepts and
Pulse Generator Operations**

Pulse Concepts and Pulse Generator Operation

Counter Architecture Overview

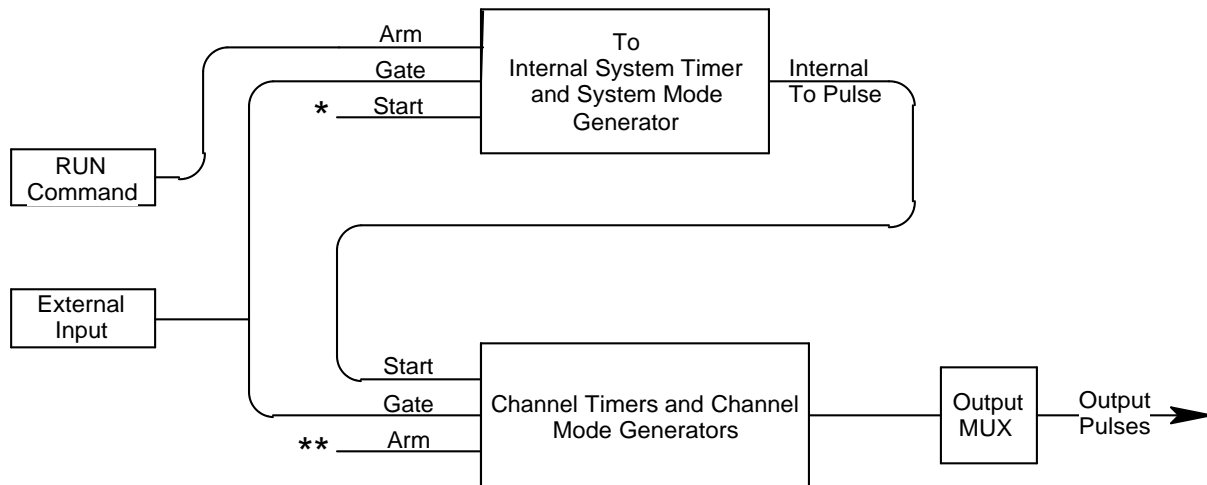

*Start source is: RUN button in Internal Modes
External input in External Trigger modes
*TRG command via Serial/GPIB access

**Channels are armed by the RUN button. In single shot and burst modes channels may be rearmed by pressing the RUN button.

System Timer Functions

The System Timer functions as a non-retriggerable, multi-vibrator pulse generator. This means that once started, depending on the mode, the timer will produce pulses continuously. Before pulses can be generated, the timer must be armed and then receive a start pulse. Arming the counter is done by pressing the **RUN/STOP** key. With external trigger disabled, the **RUN/STOP** key also generates the start command for the counter. With external trigger enabled, the external trigger provides the start pulse. In either case, once started, the counter operation is determined by the System Mode Generator. Standard modes include:

- Continuous Once started T_o pulses are generated continuously.
- Single Shot One T_o pulse is generated for each start command.
- Burst 'n' T_o pulses are generated for each start command.
- Duty Cycle Once started T_o pulses cycle on and off continuously.

The T_o pulses are distributed to all of the start inputs of the Channel Timers and Mode Generators

Channel Timer Functions

The Channel Timer functions as a non-retriggerable, delayed, one shot pulse generator. This means that the timer will only generate one delayed pulse for every start pulse received. Once the channel timer has started counting, additional start pulses will be ignored until the pulse has been completed (non-retriggerable). The start pulse for each channel is provided by the internal T_0 pulse generated by the Internal System Timer. Whether or not a pulse is generated for each T_0 pulse is determined by the Channel Mode Generator. Standard modes include:

- Normal A pulse is generated for each T_0 pulse.
- Single Shot One pulse is generated at the first T_0 pulse, after which output is inhibited.
- Burst A pulse is generated for each T_0 pulse, 'n' times, after which output is inhibited.
- Duty Cycle 'n' pulses are generated for each T_0 pulse after which the output is inhibited for 'm' times. The cycle is then repeated.

Different modes may be selected for each output, allowing a wide variety of output combinations. Each output may also be independently disabled or gated (using the external gate input).

Output Multiplexer

The output of the Channel Timers are routed to a set of multiplexers. This allows routing of any or all Channel Timers to any or all of the unit outputs. In the normal mode of operation, the output of the nth Channel Timer is routed to the Tnth output connector. As an example, if a double pulse is required on Channel A output, one can multiplex the Channel A timer with the Channel B timer adjusting each timer to provide the necessary pulses.

Dependent & Independent Timing Events

The 575 allows the user to control the relationship between the Channel Timers by setting the sync source for each timer. Independent events are all timed relative to the internal T_0 start pulse. Dependent events may be linked together by setting the sync source to the controlling event. This allows the instrument to match the timed events and adjustments can be made in one event without detuning the timing between it and a dependent event.

Navigating the 575 Front Panel

Selecting Menus

Parameters are grouped in menus, selectable using the function keys. To select the output channel parameters press the letter key corresponding to the desired channel. To select other menus, including the advanced channel menus, press the **FUNC** key and then the key corresponding to the desired function.

Menus may include a number of different pages. Each page containing up to four parameters. The status block in the upper-left corner of the display shows a vertical arrow if the current menu contains additional pages. To select the next page, press the channel button again or select the same menu pressing the **FUNC** key and the channel/menu key again.

Selecting Menu Items

Within a menu, the blinking cursor indicates the current menu item for editing. The **NEXT** key or pressing the adjustment knob will select a different menu item.

Numeric Input Mode

When the current item is numeric, the system enters the Numeric Input Mode. In this mode data may be edited in one of three ways. Using the arrow keypad, the Left and Right arrow keys are used to select a digit to edit. The selected digit blinks to identify itself as the active digit. The Up and Down arrow keys are then used to increment or decrement this digit. Alternately, after using the Left and Right arrow keys to select an active digit, the adjustment knob may be used to increment and decrement this digit. The adjustment knob features speed dependent resolution. Slow rotation will increment or decrement the active digit by one. As you increase the speed of rotation, the parameter will be 10 to 1000 times faster depending on the speed.

The last entry mode is using the numeric keypad. Enter the number, including decimal point using the numeric keypad. Complete the number using the **ENTER** key. Errors may be corrected using the backspace key or to start over press the clear key (CLR). Pressing the **CLR** key a second time will exit the numeric keypad mode and restore the original number.

Entering Non-Numeric Parameters

When the current item is non-numeric, the Up and Down arrow keys are used to select among different options for the parameter. The adjustment knob may also be used to change the selection. If the item is an on-off toggle, the Up arrow (CW adjustment knob) enables the item and the Down arrow (CCW adjustment knob) disables the item.

Alphanumeric Input Mode

When the current item is alphanumeric, the system enters the Alphanumeric Input Mode. In this mode, data is entered using the alphanumeric keypad. When entering alphanumeric values, pressing a key will display the first letter shown on the keypad. Repeated key presses will toggle through all the letters, both upper and lower case, shown on the key cap. To enter two letters which appear on the same key cap, select the first character, then use the right arrow to shift to the next position and enter the next letter. The Left and Right arrow keys may be used to position the cursor to edit any character. When data entry is complete, the ENTER key must be pressed. The keys contain the following characters:

- 1 1 2 3 4 5 6 7 8 9 0
- 2 A B C a b c 2

- 3 DEFdef3
- 4 GHIghi4
- 5 JKLjkl5
- 6 MNOmno6
- 7 PQRSpqrs7
- 8 TUVtuv8
- 9 WXYZwxyz9
- 0 0123456789
- . ., # \$ % & ?
- - - + * / space

Enabling System Output

The RUN/STOP key is used to arm the system. With external trigger disabled, the key will arm and start pulse output. With external trigger enabled, the key will arm the pulse generator. Pulse output then starts after the first valid trigger input. Pressing the RUN/STOP key a second time disables the pulse generator.

Enable/Disable Channel Output

At the top of each channel menu page is a parameter to enable or disable the output of the channel. Each channel may be individually enabled or disabled.

Rearming the Channel Timers

In the channel single shot mode and burst mode, the Channel Timers may be rearmed after completing the initial output by pressing the **FUNC** key and **RUN/STOP** key. If there are channels currently running in normal mode, single shot and burst channels can be re-armed without affecting the timing on normal mode channels by pressing function **RUN/STOP**.

Setting Pulse Timing Parameters

Pulses are defined by a delay, from their sync or start pulse to the active edge, and a width.

- Wid: Sets the width of the active portion of the pulse.
- Dly: Sets the delay from the sync source to the start of the pulse.

NOTE: If $Wid + Dly + 75ns$ (hardware reset time) $> T_o$ Period, the correct pulsewidth will be generated but at a slower rate.

Setting Pulse Output Parameters

There are three basic types of outputs available on the 575: (a) TTL/CMOS compatible outputs; (b) adjustable amplitude outputs; (c) optical outputs.

Out:	Selects between TTL/CMOS mode and Adjustable mode when both are available on a single output.
Pol:	Sets the voltage polarity of the pulse, active high or active low. Note: All outputs are positive - negative voltages are not supported.
Ampl:	In adjustable mode, it sets the unloaded output voltage. The actual output voltage will depend on the load impedance. For example: If the load is 50 ohms, the output will be 50% of the stated voltage.

Using the Output Multiplexer

Each output channel includes a multiplexer which allows routing any or all of the timer outputs to the physical output. This allows double pulses and other complex pulse trains to be generated.

-HGFEDCBA-

Mux: -00000101-

The multiplexer is represented by a “n” bit binary number as shown above. “n” is the number of channels. Each bit represents a channel timer, which is enabled by setting the bit to one. In the above example, timers A and C are combined on the current output.

Setting System Internal Rate Parameters

The internal T_o period controls the fundamental output frequency of the system. Each channel may operate at submultiples of the fundamental frequency using their duty cycle mode.

Source:	Sets the reference source for the internal T_o Period.
Per:	Sets the internal T_o Period.

To set the system Internal Rate - press the yellow **FUNC** key, then press the **RATE** key, and then use the dial or number pad to specify the T_o Period.

575 Menus

575 Menu Structure

System MODE Menus

To Mode	To Mode	To Mode	To Mode
MODE: Continuous	MODE: Single Shot	MODE: Burst	MODE: Duty Cycle
			# / On
		# / Burst	# / Off

CHANNEL Menus

Timing Parameters	Pulse Configuration	Pulse Configuration
Channel Enable	Channel Enable	Channel Enable
	Polarity	Polarity
Pulsewidth	Output Type: TTL, Optical	Output Type: Adjustable
Delay		Output Level

Channel Mode	Channel Mode	Channel Mode	Channel Mode	Wait Menu	Multiplexer Menu
Channel Enable	Channel Enable	Channel Enable	Channel Enable		Channel Enable
Mode: Normal	Mode: Single Shot	Mode: Burst	Mode: Duty Cycle		Help Line
			# / On		Mux
			# / Off	Wait Count	

Advanced CHANNEL Menus

Advanced Timing Parameters	Advanced Timing Parameters	Channel Gated Operation	Channel Gated Operation
Channel Enable	Channel Enable	Channel Enable	Channel Enable
SyncSource	Sync Source	Gate Enable: Disabled	Gate Enable: <method>
			Gate Polarity

RATE Menu

Rate Source	Reference Out
Source	Ref Out
To Period	

TRIG Menu

Trig Mode	Trig Mode
Trig Disabled	Trig: <trig mode>
	Threshold
	Edge

GATE Menu

Gate Mode	Gate Mode
Gate Disabled	Gate: Enabled
	Threshold
	Polarity

SYSTEM Menus

Comm. Parameters	Comm. Parameters	Comm. Parameters	Keypad Parameters	Misc. Parameters
Interface: RS232	Interface: USB	Interface: GPIB	Key Repeat Rate	Auto Start
Baud Rate	Baud Rate	Address	Key Volume	Decimal Mark
Echo Enable			Knob Volume	LCD Brightness

STORE Menu

Store Menu
Configuration #
Name
Help Line

RECALL Menu

Recall Menu
Configuration #
Name
Help Line

System Mode Menu

To Mode	To Mode	To Mode	To Mode
MODE: Continuous	MODE: Single Shot	MODE: Burst	MODE: Duty Cycle
			On Cycle
		# / Burst	Off Cycle

Setting System Mode of Operation

The MODE menu sets the T_o system timer mode. The menu will show the extra set parameters (Burst, On & Off) only when they are appropriate.

- Mode: Selects the T_o mode: Continuous, Single Shot, Burst or Duty Cycle mode.
- Burst: Sets the number of pulses to be generated when in Burst mode.
- On: Sets the number of pulses to be generated during each on cycle.
- Off: Sets the number of pulses to skip each during off cycle when in the Duty Cycle mode.

**NOTE: Any mode may be started by either the RUN/STOP key in the internal trigger mode or armed by the RUN/STOP key and started by an external trigger in the external trigger mode. In the single shot and burst modes, (internally triggered) the unit disarms itself at the end of the pulse train. Pressing the RUN/STOP key after the unit has been disarmed will generate a new pulse train.*

Channel Menus

Timing Parameters	Pulse Configuration	Pulse Configuration
Channel Enable	Channel Enable	Channel Enable
	Polarity	Polarity
Pulsewidth	Output Type: TTL, Optical	Output Type: Adjustable
Delay		Output Level

Channel Mode	Channel Mode	Channel Mode	Channel Mode	Wait Menu	Multiplexer Menu
Channel Enable	Channel Enable	Channel Enable	Channel Enable		Channel Enable
Mode: Normal	Mode: Single Shot	Mode: Burst	Mode: Duty Cycle		Help Line
			# / On		Mux
			# / Off	Wait Count	

Enabling Channel Output

At the top of each of the channel menu pages is a parameter to enable or disable the channel. Each channel may be individually controlled.

Setting the Channel Timing Parameters

To define a pulse requires two parameters: the delay to the active edge and the width of the pulse.

Wid:	Sets the channel pulsewidth.
Dly:	Sets the channel delay until the active edge.

Setting Pulse Output Configuration

The 575 supports two types of outputs: a high speed TTL/CMOS compatible output and for applications which require different voltage levels or higher current, an adjustable voltage output. The pulses can also be defined to be active high or active low.

Pol:	Sets the pulse polarity, active high or active low.
Out:	Selects the output mode, TTL/CMOS or Adjustable
Ampl:	Sets the output voltage level when in the Adjustable mode.

Setting Pulse Mode of Operation

Each channel may be set independently to operate in one of four modes: normal, single shot, burst, or duty cycle (within the **CHANNEL** menus):

Mode:	Selects the mode for the current channel. Additional parameters are provided for the burst mode and the duty cycle mode.
Brst:	Sets the number of pulses in the burst mode to generate before inhibiting output.
On:	Sets the number of pulses to generate before inhibiting output in Duty Cycle Mode.
Off:	Sets the number of pulses to inhibit before repeating the On Cycle in Duty Cycle Mode.

Delaying the Start of Channel Output

Within any channel mode, the output of the channel can be delayed using the wait parameter (within the **CHANNEL** menu):

Wait:	Sets the number of T_o pulses to wait until enabling the channel output.
-------	--

Configuring the Channel Multiplexer

To define which channels are fed into the channel multiplexer, the corresponding bit for the desired channel to add should be set to 1. All desired omitted channels should have the corresponding bit set to 0.

Mux: Enable/disable bitfield.

Advanced Channel Menus

Advanced Timing Parameters	Advanced Timing Parameters	Channel Gated Operation	Channel Gated Operation
Channel Enable	Channel Enable	Channel Enable	Channel Enable
SyncSource	Sync Source	Gate Enable: Disabled	Gate Enable: <method>
			Gate Polarity

Setting the Sync Source

Although each channel receives its start pulse from the internal T_0 pulse, logically the start pulse can be assigned such that the delay entered is relative to the T_0 pulse or any other channel pulse. This allows dependent events to link. The unit will not allow a circular chain of sync sources that would result in a channel triggering itself. The delay entered is relative to the selected sync source.

Sync Source: Selects the channel sync source.

Setting Channel Gate Control

When the global gate is set (Chan Menu), the channel can then use the gate input with independent behavior from other channels.

Gate: Enables the **GATE** input for the channel by setting the method of output control used with the gating function.

Logic: Sets the logic level used with the gating function, either active high or active low.

“Pulse Inhibit” method - the gate prevents the channel from being triggered by the channel’s trigger source pulse. If a pulse has already started when the gate disables the channel, the pulse will continue normal output but will not restart on the next trigger pulse.

“Output Inhibit” method - the gate leaves the base triggering alone and enables/disables the output directly.

Gate Menu

Gate Mode	Gate Mode
Gate: Disabled	Gate: <method>
	Threshold
	Polarity

Enabling System Gate

Enables the use of the GATE input as a trigger inhibit or output control for all channels simultaneously, or on a per channel basis.

Mode: Selects between disabling the **GATE** inputs and method of output control
Level: Sets the gating threshold.
Logic: Sets the active logic level.

Trig Menu

Trig Mode	Trig Mode
Trig: Disabled	Trig: <trig mode>
	Threshold
	Edge

Enabling System Trigger

Enable the use of the **TRIG** input by the system timer as a trigger source.

Mode: Selects between disabling/enabling the trigger mode(s).
Level: Sets the trigger threshold.
Edge: Selects between rising edge / falling edge as the trigger source when a trigger mode is enabled.

Rate Menu

Rate Source	Reference Out
Source	Ref Out
To Period	

Setting the Clock Source and Internal Rate

Source: Selects the internal or external clock source from which the unit will operate.
Per: Sets the T_o period which determines the fundamental output frequency of the unit.

Setting the Output Reference

Ref Out: Selects the frequency of the output reference for synchronizing with external system components.

System Menu

Comm. Parameters	Comm. Parameters	Comm. Parameters	Keypad Parameters	Misc. Parameters
Interface: RS232	Interface: USB	Interface: GPIB	Key Repeat Rate	Auto Start
Baud Rate		Address	Key Volume	Decimal Mark
Echo Enable			Knob Volume	LCD Brightness

Setting System Communication Parameters

The 575 comes with a standard RS232 serial port and USB port. The unit will not respond to computer commands unless these ports are properly configured.

Interface:	RS232, USB, GPIB (optional), Ethernet (optional)
Baud Rate:	Selects the baud rate for the selected interface.
Echo:	Selects whether to echo characters back to the host computer or not.
Address:	Sets the GPIB address.

Setting Keypad Parameters

The rate at which a key will repeat itself when held down may be set. This can be used to provide a controlled rate at which a parameter is incremented. In addition, the volume of the beep can be controlled for both the keypad and the adjustable knob.

Key Rate:	Sets the rate at which the keys will repeat when held down.
Key Vol:	Sets the beep volume for the keypad.
Knob Vol:	Sets the beep volume for the Rotary Knob.

Setting the Auto Start Mode

The unit may be configured to automatically start generating pulses after power up.

Setting the Display Decimal Mark

Mark:	Selects the format of the decimal mark, "." or ",".
-------	---

Setting the Display Brightness

LCD	Adjusts display brightness.
-----	-----------------------------

Store Menu

Store Menu
Configuration #
Name
Help Line

Storing a Configuration

Use the following procedure to store a complete system configuration:

- Set all parameters to the desired value.
- Select a configuration number.

**NOTE: You cannot store to the zero location, as that contains the factory default values.*

- Label the configuration as desired.
- From the Store menu, press the store button sequence (FUNC + store).

**NOTE: When the unit powers up it will recall the last stored or recalled configuration. Any changes to the configuration which were not saved are not restored.*

Recall Menu

Recall Menu
Configuration #
Name
Help Line

Recalling System Configurations

Use the following procedure to recall a stored or default system configuration:

- Enter the Recall Menu (FUNC + recall).
- Select a configuration number.
- From the Recall Menu, press the recall key sequence (function + recall).

**Note: Configuration 0 is the factory default setting.*

Operating the 575

Quick Start - Normal Internal Rate Generator Operation

The 575 has a powerful set of functions providing a number of modes of operation for the internal or “System” rate generator (T_o). Most of these functions can be ignored if a simple continuous stream of pulses is required. Starting from the default settings, which can be recalled by recalling configuration 0, the following parameters need to be set:

Pulse Width, Delay	Enter the Channel menus by pressing the letter key. Enter the required pulse width and delay. Repeat for each output channel.
T_o Period	Enter the Rate menu by pressing the FUNC key and then the RATE key. Set the desired pulse period. Note that in general, the pulse delay plus the pulse width, plus a 75ns hardware reset constant, for any channel must be less than the T_o period.
Start	Press the RUN/STOP key to start generating pulses.
Stop	Press the RUN/STOP key a second time to stop generating pulses.

Quick Start - Normal External Trigger Operation

To generate a single pulse for every external trigger event, based on the default configuration 0, the following parameters need to be set:

System Mode	Enter the MODE menu by pressing the FUNC key and then the MODE key. Select Single Shot mode.
Trig	Enter the TRIG menu by pressing the TRIG key. Select Triggered.
Level	Press the NEXT key until the Level parameter is displayed. Set the trigger threshold voltage to approximately 50% of the trigger signal amplitude.

Edge	Press the NEXT key until the Edge parameter is highlighted. Set the instrument to trigger off the rising edge or falling edge as desired.
Pulse Width, Delay	Enter the Channel menus by pressing the letter key. Enter the required pulse width and delay. Repeat for each output channel.
Start	Press the RUN/STOP key to start/arm the instrument. The 9520 will now generate a pulse for every valid trigger.
Stop	Press the RUN/STOP key a second time to stop/disarm the instrument (i.e. to stop generating pulses).

System Timer Overview

For internal operation, the 575 contains a timer and mode generator which generates an internal T_0 clock that is used to trigger all the channel timers. System modes are controlled via the **MODE** menu.

To Use Continuous Mode

The **RUN/STOP** button starts and stops a continuous pulse stream at the rate specified by the Rate menu. This corresponds to the normal output mode for most pulse generators. To generate a continuous stream of pulses:

- within the system **Mode** menu

Mode Select Continuous for the system mode.

- within the **Rate** menu

Source Select the system oscillator or the external clock in frequency.

Period Set the desired period.

Pressing the **RUN/STOP** key will now generate a stream of T_0 pulses, at a rate specified by the period parameter.

To Use Single Shot Mode

To generate a single pulse with every press of the **RUN/STOP** key:

- within the system **Mode** menu

Mode Select Single Shot for the system mode.

Pressing the **RUN/STOP** key will now generate a single pulse.

To Use System Burst Mode Function

The **RUN/STOP** button generates a stream of “n” T_o pulses, where “n” is specified by the Burst parameter. The rate is specified in the Rate menu. Pressing the **RUN/STOP** button while the burst is in process will stop the output. After the burst has been completed, pressing the **RUN/STOP** button will generate another burst. To generate a burst of pulses:

- within the system **Mode** menu

Mode: Select the Burst mode.

Burst: Set the number of pulses to produce in the burst.

To Use System Duty Cycle Function

The **RUN/STOP** button starts a continuous pulse stream which oscillates on for the “n” pulses and off for “m” pulses, where “n” and “m” are specified by the On and Off parameters, respectively. The rate is specified in the Rate Menu. To generate a stream of pulses which oscillates on for ‘n’ pulses and off for ‘m’ pulse:

- within the system **ModeE** menu

Mode: Select the Duty Cycle mode.

On: Set the number of pulses to produce during the on cycle.

Off: Set the number of pulses to skip during the off cycle.

-within the **Rate** menu

Source Select the system oscillator or the external clock in frequency.

Period: Set desired Period.

Channel Timer Overview

The output of each channel is controlled by two timers to generate the delay timing and the pulsewidth. All channels are simultaneously triggered, depending on the system mode, by either the internal T_o pulse, the external trigger, or a trigger provided by a cpu. A given channel may or may not generate a pulse depending on its own channel mode as described below.

When one channel is generating a continuous stream of pulses, a user can trigger a single shot or burst of pulses on another channel without interrupting the continuous stream by pressing “**FUNC**” and “**RUN/STOP**”.

To Use Channel Normal Mode Function

The Normal mode generates a continuous stream of pulses at a rate determined by the system timer:

- within the **Channel** menus

Enable: Select Enable to enable channel output.

Dly: Set the desired delay.

Wid: Set the desired pulsewidth.
Mode: Select the Normal mode.

Pressing the **RUN/STOP** key will now generate a continuous stream of pulses.

To Use Channel Single Shot Function

The Single Shot mode generates a single pulse every time the **RUN/STOP** key is pressed. If the unit is in the active state, (i.e. channels which are set to the Normal mode are producing pulses), pressing the “**FUNC**” key and **RUN/STOP** key will reset the Single Shot counters and generate one pulse in sync with the other channels running in the Normal mode. To use the Single Shot mode:

- within the **Channel** menus

Enable Select Enable to enable channel output.
Delay Set the desired delay.
Width Set the desired pulsewidth.
Mode Select the Single shot mode.

To Use Channel Burst Mode Function

The Burst mode generates a burst of pulses every time the **RUN/STOP** key is pressed. If the unit is in the active state, (i.e. channels which are set to the Normal mode are producing pulses), pressing the “**FUNC- RUN/STOP**” key sequence will reset the Burst counters and generate a new set of pulses in sync with the other channels running in the Normal mode. “**FUNC - RUN/STOP**” will not affect T_o pulse status. To use the Burst mode:

-within the **Channel** menus

Enable Select Enable to enable channel output.
Delay Set the desired delay.
Width Set the desired pulsewidth.
Mode Select the Burst mode.
#/Burst Set the number of pulses to produce in the burst.

To Use the Channel Duty Cycle Function

To generate a stream of pulses which oscillates on for ‘n’pulses and off for ‘m’ pulses:

- within the **Channel** menus

Enable Select Enable to enable channel output.
Delay Set the desired delay.
Width Set the desired pulsewidth.
Mode Select the Duty Cycle mode.
On Cycle Set the number of pulses to produce during the on cycle.
Off Cycle Set the number of pulses to skip during the off cycle.

Note: Older Quantum Composers pulse generators had a divide-by-n function. The duty cycle mode is a more general case. To reproduce the divide-by-n function, set the on cycle to 1 and set the off cycle to (n-1), where “n” is the divide-by-n factor.

To Use the Channel Gating Function

Each channel may use the external input to gate or control its output. The gate controls the triggering of the channel. Once a channel has started to produce a pulse it will complete the pulse, even if the gate has been removed - no partial pulses will be produced. To use the gate, set the following parameters

- within the **Channel** menu

Mode: In Gate Menu must be set to Channel Menu.
Channel Gate: Select pulse INH or output INH.
Logic: Select active high or active low.

In “Pulse” method, the gate prevents the channel from being triggered by the channel’s trigger source pulse. If a pulse has already started when the gate disables the channel, the pulse will continue normal output but will not restart on the next pulse. In “Output” method, the gate leaves the base triggering alone and enables/disables the output directly.

External Input Overview

The external inputs may be used to trigger the unit or to gate the system or channel timers. When using a trigger input, the external input acts as a system start pulse. Depending on the system mode, the result of a trigger input can be either a single pulse, a burst of pulses or the start of a stream of pulses.

To Generate a Pulse on Every Trigger Input

To generate a pulse on every external trigger received, set the following parameters:

- within the **Mode** menu

Mode: Select the Single Shot mode.

- within the **Trigger** menu

Mode: Select Triggered mode.
Level: Set the trigger threshold level.
Edge: Select which edge, rising or falling, to trigger on.

Pressing the **RUN/STOP** key will arm the unit. Once the unit is armed, it will generate a T_o pulse for every external trigger received. Pressing the **RUN/STOP** key will disarm the unit. This mode corresponds to the normal external trigger mode found on most other pulse generators.

To Generate a Burst of Pulses on Every Trigger Input

To generate a burst of pulses for every external trigger received set the following parameters:

-within the **Mode** menu

- Mode: Select the Burst mode.
- Burst: Set the number of pulses to generate in each burst.-
within the Rate menu
- Per: Set the period between pulses.

- within the **Rate** menu

- Source: Select the system oscillator or an external clock in frequency.
- Per: Set the period between pulses.

- within the **Trigger** menu

- Mode: Select Triggered mode.
- Level: Set the trigger threshold level.
- Edge: Select which edge, rising or falling, to trigger on.

Pressing the **RUN/STOP** key will arm the unit. Once the unit is armed, it will generate a set of pulses for every external trigger received. The unit is reset at the end of a burst and will generate another set of pulses upon receiving a new trigger. Triggers that occur in the middle of a burst are ignored. Pressing the **RUN/STOP** key will disarm the unit.

To Start a Continuous Stream of Pulses Using the External Trigger

The external trigger may be used to start the unit generating pulses:

- within the **Mode** menu

- Mode: Select the Continuous mode.

- within the **Rate** menu

- Source: Select the system oscillator or an external clock in frequency.
- Per: Set the period between pulses.

- within the **Trigger** menu

- Mode: Select the Trigger mode.
- Level: Set the trigger threshold level.
- Edge: Select which edge, rising or falling, to trigger on.

Pressing the **RUN/STOP** key will arm the unit. Once the unit is armed, it will begin generating pulses after an external trigger is received. Triggers that occur after the pulses start are ignored. Pressing the **RUN/STOP** key a second time will disarm the unit.

To use the External Gate to Control the System

The external gate may be used to control the output of the unit. To gate the system timer:

- within the **Gate** menu

Mode: Select Gate Menu
Gate: Select active high or active low.
Level: Set the threshold voltage for the external input.
Method (advanced): Select Pulse or output (press Function Key and then hit Channel Key; repeat to cycle through Advanced Channel Menu.

- within the **Mode** menu

Mode: Select the desired mode.

- within the **Rate** menu

Source: Select the system oscillator or an external clock in frequency..
Per: Set the period between pulses.

- within the **Gate** menu

Mode: Select pulse INH or output INH.
Level: Set the gate threshold level.
Logic: Select active high or active low.

Pressing the **RUN/STOP** key will arm the unit. Once the unit is armed, it will begin generating pulses whenever the external gate input is in the active state. Pressing the **RUN/STOP** key a second time will disarm the unit.

Programming the 575

Personal Computer to Pulse Generator Communication

The 575 comes standard with RS232 and USB; Ethernet and GPIB interfaces are optional. All menu settings can be set and retrieved over the computer interface using a simple command language. The command set is structured to be consistent with the Standard Commands for Programmable Instruments. Although due to the high number of special features found in the 575, many of the commands are not included in the specification. The syntax is the same for all interfaces.

RS232 Interface Overview

The serial port is located on the back of the 575 and uses a 9-pin D-type connector with the following pinout (as viewed from the back of the unit):

- | | |
|---|------------------------------|
| 1 | No Connection |
| 2 | Tx - Transmit (to computer) |
| 3 | Rx - Receive (from computer) |
| 4 | DTR - Connected to pin 6 |
| 5 | Ground |
| 6 | DSR - connected to pin 4 |
| 7 | RTS - connected to pin 8 |
| 8 | CTS - connected to pin 7 |
| 9 | No Connection |

The serial port parameters should be set as follows:

Baud Rate	4800, 9600 19200, 38400, 57600, 115200 (default)
Data Bits	8
Parity	None
Stop Bits	1

* The default baud rate for the RS232 interace is 115200.

USB Interface Overview

The USB interface is standard on the 575. Before this type of communication can be used, the appropriate drivers must be installed on the personal computer (pc). These drivers are included on the cd that was shipped with your unit. Please contact Berkeley Nucleonics or visit www.berkeley-nucleonics.com for updated installation files and instructions.

USB communication is achieved by using a mapped (virtual) COM port on the pc. The driver installation executable will obtain an unused COM port number,

install the USB drivers, and make that COM port number available for typical RS232 communication to the pulse generator. Hyperterminal or other common software may be used.

When communicating through the mapped COM port over USB, the baud rate for the communication port used by the USB chip must match the baud rate for the COM port on the pc. Access to the USB port baud rate is done using the SCPI command “:SYSTem:COMMunicate:SERial:USB n” command, where ‘n’ is the desired communication speed. This parameter can be accessed via any communication method. The default baud rate for USB is 38400.

USB communication notes:

- The correct drivers must be installed on the personal computer before communication can be accomplished via USB.
- The BAUD rates on the pc and on the pulse generator must match for successful communication.
- The USB port’s BAUD rate on the pulse generator can be set using the SCPI command “:SYSTem:COMMunicate:SERial:USB n” where ‘n’ can be:
 - o 4800
 - o 9600
 - o 19200
 - o 38400 (default)
 - o 57600
 - o 115200
- USB 1.0 specification is used. The USB cable can be removed without “unplugging” the device in the operating system environment.
- Echo functionality is not available on the USB port.

GPIB Interface Overview

Also known as IEEE-488, a GPIB computer interface is standard on the 575. Before using this interface, the address must be set using the GPIB address menu item. The command set is the same for the RS-232, GPIB, USB and Ethernet. Different interfaces may be used at the same time. Responses will be made to the most recently used interface.

Ethernet Interface Overview

An Ethernet interface is optional on the 575.

The Ethernet module used is a “Digi Connect ME” module supplied by Digi Connectware, Inc. There are several ways to successfully communicate with the pulse generator over Ethernet. The two most popular methods are raw TCP/IP (such as Labview or programming with VISA libraries) and by mapping a pc COM port using the Digi Connectware’s “Realport Drivers”.

Whatever method of Ethernet communication is ultimately desired, the utilities supplied by Digi Connectware (included on the cd shipped with the Ethernet-option pulse generator) will be critical to implementing the communications. Please install these utilities.

Ethernet communication notes:

- The Digi Connectware’s “Digi Device Discovery” can be used to determine what IP address was assigned by the local DHCP server (if any).
- “Digi Device Discovery” can also be used to open a web interface to the Ethernet module. Simply double-click on the IP address that is displayed in the Digi Device Discovery utility.
 - o Username: “root”
 - o Password: “dbps”
- If a mapped COM port is the desired communication method, the Digi Connectware’s “Realport Drivers” setup must be used to install the COM port on the pc. This virtual COM port is then local to the computer it was installed on. Please refer to the Digi Connectware documentation supplied on the cd, or call Quantum Composers technical support.
- The pulse generator’s SCPI parameter “:SYSTEM:COMMunicate:SERial:USB n” is defaulted to 115200 and should not be changed for Ethernet communication, whether or not a mapped COM port is used. The virtual COM port on the pc should be set to 115200 BAUD.
- Echo functionality is not available on the Ethernet port.

Programming Command Types and Format

The 575 Pulse Generator uses two types of programming commands: IEEE 488.2 Common Commands and Standard Commands for Programmable Instruments (SCPI). The format is the same for all interfaces. Hyperterminal (in Windows) or any other generic terminal program may be used to interactively test the commands using the RS232 interface. The format of each type is described in the following paragraphs.

Line Termination

The pulse generator uses text-style line terminations. When a command is sent to the unit, the firmware is programmed to read characters from a communication port until it reads the line termination sequence.

The command string is parsed and executed after reading these characters. These characters are the “carriage return” and “linefeed”. They are ascii character set values 13 and 10 respectively (hex 0x0D and 0x0A). All command strings need to have these characters appended.

When the pulse generator responds to a command, whether it is a query or a parameter change, it also appends its return strings with these characters. Coded applications could use this behavior to know when to stop reading from the unit. However, if the “echo” parameter is enabled, there will be two sets of line terminators, one following the echoed command string, and one following the pulse generator’s response.

Note: The pulse generator will echo commands on the DB9 serial port only.

The pulse generator responds to every communication string. If the communication string is a query, the unit responds with the queried response (or error code) followed by the line terminators. If the communication string is a parameter change, the response is “ok” (or error code) followed by the line terminators. For this reason, it is not recommended that multiple commands be stacked together into single strings as is common with some other types of instruments. It is recommended that the coded application send a single command in a string and follow immediately by reading the response from the unit. Repeat this sequence for multiple commands.

IEEE 488.2 Common Command Format

The IEEE 488.2 Common Commands control and manage generic system functions such as reset, configuration storage and identification. Common commands always begin with the asterisk (*) character and may include parameters. The parameters are separated from the command mnemonic by a space character. For Example:

```
*RST      <cr> <lf>
*RCL 1    <cr> <lf>
*IDN?    <cr> <lf>
```

SCPI Command Keywords

The commands are shown as a mixture of upper and lower case letters. The upper case letters indicate the abbreviated spelling for the command. You may send either the abbreviated version or the entire keyword. Upper and/or lower case characters are acceptable.

For example, if the command keyword is given as POLarity, then POL and POLARITY are both acceptable forms; truncated forms such as POLAR will generate an error; polarity, pol, and PolAriTy are all acceptable as the pulse generator is not case sensitive.

SCPI Command Format

SCPI commands control and set instrument specific functions such as setting the pulsewidth, delay and period. SCPI commands have a hierarchical structure composed of functional elements that include a header or keywords separated with a colon, data parameters and terminators. For example:

SCPI Format

```
:PULSE1:STATE ON           <cr> <lf>
:PULSe1:WIDTh 0.000120    <cr> <lf>
:PULSe:POL NORMal        <cr> <lf>
```

Any parameter may be queried by sending the command with a question mark appended. For example:

- QUERY FORMAT

:PULSE1:STATE?

Will return: 1 <cr><lf>

:PULSE1:WIDTh? <cr><lf>

Will return: 0.000120000 <cr><lf>

:PULSE1:POL? <cr><lf>

Will return: NORM <cr><lf>

SCPI Keyword Separator

A colon (:) must always separate one keyword from the next lower-level keyword. A space must be used to separate the keyword header from the first parameter. If more than one parameter is used, you must separate subsequent parameters with a comma.

SCPI Optional Keywords

Optional keywords and/or parameters appear in square brackets ([]) in the command syntax. Note that the brackets are not part of the command and should not be sent to the pulse generator. When sending a second level keyword without the optional keyword, the pulse generator assumes that you intend to use the optional keyword and responds as if it had been sent.

SCPI Specific and Implied Channel

Some commands, such as PULSe, allow specifying a channel with an optional numeric keyword suffix. The suffix will be shown in square brackets [1 / 2]. The brackets are not part of command and are not to be sent to the pulse generator. The numeric parameters correspond to the following channels: 0 = To, 1 = ChA, 2 = ChB, etc. Only one channel may be specified at a time.

If you do not specify the channel number, the implied channel is specified by the :INSTrument:SElect command or the last referenced channel.

After power-up or reset (*RST) The instrument default is channel #1.

SCPI Parameter Types

The following parameter types are used:

<numeric value>	Accepts all commonly used decimal representation of numbers including optional signs, decimal points and scientific notation: 123, 123e2, -123, -1.23e2, .123, 1.23e-2, 1.2300E-01.
<boolean value>	Represents a single binary condition that is either true or false. True is represented by a 1 or ON; false is represented by a 0 or OFF. Queries return 1 or 0.
<identifier>	Selects from a finite number of predefined strings.

Error Codes

The unit responds to all commands with either:

ok <cr><lf> or ?n <cr><lf>

Where "n" is one of the following error codes:

- 1 Incorrect prefix, i.e. no colon or * to start command.
- 2 Missing command keyword.
- 3 Invalid command keyword.
- 4 Missing parameter.
- 5 Invalid parameter.
- 6 Query only, command needs a question mark.
- 7 Invalid query, command does not have a query form.
- 8 Command unavailable in current system state.

Programming Examples

Example 1) 20 ms pulsewidth, 2.3 ms delay, 10 Hz, internal trigger, continuous operation.

:PULSE1:STATE ON <cr> <lf>	enables channel A
:PULSE1:POL NORM <cr> <lf>	sets polarity to active high
:PULSE:WIDT 0.020 <cr> <lf>	sets pulsewidth to 20 ms
:PULSE1:DELAY 0.0023 <cr> <lf>	sets delay to 2.3 ms
:PULSE0:MODE NORM <cr> <lf>	sets system mode to continuous
:PULSE0:PER 0.1 <cr> <lf>	sets period to 100 ms (10 Hz)
:PULSE0:EXT:MODE DIS <cr> <lf>	disables the external trigger

To start the pulses use either of the following commands:

:PULSE0:STATE ON <cr> <lf>	starts the pulses
:INST:STATE ON <cr> <lf>	alternate form to start pulses.

Example 2) 25 μ s pulsewidth, 0 delay, external trigger, one pulse for every trigger.

:PULSE1:STATE ON <cr> <lf>	enables channel A
:PULSE1:POL NORM <cr> <lf>	sets polarity to active high
:PULSE:WIDT 0.000025 <cr> <lf>	sets pulsewidth to 25 μ s
:PULSE1:DELAY 0 <cr> <lf>	sets delay to 0
:PULSE0:MODE SING <cr> <lf>	sets system mode to single shot
:PULSE:TRIG:MODE TRIG <cr> <lf>	sets system to external trigger
:PULS:EXT:LEV 2.5 <cr> <lf>	sets trigger level to 2.5 v
:PULS:EXT:EDGE RIS <cr> <lf>	set to trigger on rising edge

To arm the instrument in external gate mode, use either of the following commands:

:PULSE0:STATE ON <cr> <lf>	arms the instrument
:INST:STATE ON <cr> <lf>	alternate form if T ₀ is currently selected

A software generated external trigger can be generated by using the following command:

*TRG <cr> <lf>	generates a software external trigger
----------------	---------------------------------------

575 SCPI Command Summary

Keyword	Parameter	Std/ New	Comments
:INSTrument		Std	Subsystem. Supports treating each channel as a logical instrument.
:CATalog?		Std	Query only. Returns a comma-separated list of the names of all channels. A two channel instrument would return: T ₀ , CHA, CHB.
:FULL?		Std	Query only. Returns a comma-separated list of the names of all channels and their associated number. A two channel instrument would return: T ₀ , 0, CHA, 1, CHB, 2.
:COMMands?		New	Query only. Returns an indentured list of all SCPI commands.
:NSElect	<numeric value>	Std	Selects a channel using the channel's numeric value. All channel specific commands will refer to the selected channel.
:SElect	<identifier>	Std	Selects a channel using the channel's identifier string. All subsequent channel specific commands will refer to the selected channel.
:STATe	<boolean value>	Std	Enables/Disables the selected channel output. If T ₀ is selected all output is affected. Enabling T ₀ is the same as pressing the RUN button.

575 SCPI Command Summary

Keyword	Parameter	Std/ New	Comments
[:PULSe] [0]		Std	Subsystem. Contains commands to control the output pulse generation. Commands without suffix refer to the currently selected logical instrument. See INSTRument subsystem.
:STATe	<boolean value>	Std	Enables / Disables the output for all channels. Command is the same as pressing the RUN/STOP button.
:PERiod	<numeric value>	Std	Sets the To period.
:MODE	NORMal / SINGle / BURSt / DCYClE	New	Sets the To mode.
:BCOunter	<numeric value>	New	Burst Counter. Number of pulses to generate in the Burst mode.
:PCOunter	<numeric value>	New	Pulse Counter. Number of pulses to generate during on cycle of the Duty Cycle mode.
:OCOunter	<numeric value>	New	Off Counter. Number of pulses to inhibit output during the off cycle of the Duty Cycle mode.
:CLock	SYS/ EXT10/ EXT20/ EXT25/ EXT40/ EXT50/ EXT80/ EXT100	New	Sets Source for the external rate generator. System Clock or External Source ranging from 10MHz to 100MHz.
:OCLock	To / 10 / 11 / 12 / 14 / 16 / 20 / 25 / 33 / 50 / 100	New	Sets external clock output. To Pulse or 50% duty cycle TTL output from 10MHz to 100MHz.
:GATe		New	Subsystem. Contains the commands to define the Gate function.
:MODE	DIS/PULS/OUTP/ CHAN	New	Sets Global Gate Mode. Disable, pulse inhibit, output inhibit, channel.
:LOGic	LOW / HIGH	New	Sets Channel Gate logic level. Active low or active high.
:LEVel	<numeric value>	New	Sets the gate threshold. Value is in volts with a range of .20 to 15 Volts.
:TRIGger		New	Subsystem. Contains the commands to define the Trigger function.
:MODE	DIS / TRIG	New	Sets Trigger Mode. Disable or TRIG (enable).
:EDGE	RISing / FALLing	New	Selects which edge (rising or falling) to use as the trigger signal.
:LEVel	<numeric value>	New	Sets the Trigger Threshold. Value is in volts, with a a range of .20 to 15 Volts.

575 SCPI Command Summary

Keyword	Parameter	Std/ New	Comments
:PULSe [1 / 2 / n]		Std	Subsystem. Contains commands to control the output pulse generation. Valid suffix range depends on the number of channels (ChA = 1, ChB = 2, etc). Command without suffix refers to the currently selected logical instrument. See INSTRUMENT subsystem.
:STATe	<boolean value>	Std	Enables/Disables the output pulse for selected channel.
:WIDTh	<numeric value>	Std	Sets the width or duration of the output pulse.
:DELay	<numeric value>	Std	Sets the time from the start of the To period to the first edge of the pulse.
:SYNC	TO, CHA, CHB, CHC, CHD, etc.	New	Selects the Sync source.
:MUX	<numeric value>	New	Selects which timers are enabled as output for the current channel.
:POLarity	NORMAL / COMPLEMENT / INVERTed	Std	Sets the polarity of the pulse. For NORMAL operation the second nominal state is more positive than the first. COMPLEMENT and INVERTed are aliases. For both, the second state is more negative than the first.
:OUTPut		New	Subsystem. Contains command to control output mode.
:AMPLitude	<numeric values>	New	Sets adjustable output level.
:MODE	TTL / ADJUSTable /	New	Selects output AMPLitude mode: TTL / CMOS, ADJUSTable.
:CMODE	NORMAL / SINGLE / BURSt / DcYcLe	New	Channel Mode. Sets the channel pulse series output mode.
:BCOUNTER	<numeric value>	New	Burst Counter. Sets the number of pulses to generate when channel is in the BURST mode.
:PCOUNTER	<numeric value>	New	Pulse Counter. Sets the number of pulses to generate during the on cycle of the Duty Cycle Mode.
:OCOUNTER	<numeric value>	New	Off Counter. Number of pulses to inhibit output during the off cycle of the Duty Cycle mode.
:WCOUNTER	<numeric value>	New	Sets the number of To pulses to delay until enabling output.
:PULSE1 - n			
:CGATE	DIS / PULS / OUTP	New	Sets Channel Gate Mode. Disable, pulse inhibit, output inhibit. (Global Gate Mode must be set to CHAN for this command to be available).
:CLOGic	LOW / HIGH	New	Sets Channel Gate Logic level. Active low or active high. (Global Gate Mode must be set to CHAN for this command to be available).

575 SCPI Command Summary

Keyword	Parameter	Std/ New	Comments
:SYSTem		Std	
:STATe?		New	Query only. Returns the state of the machine: returns "1" if the machine is armed and/or generating pulses or "0" if the machine has been disarmed.
:BEEPer		Std	Subsystem. Controls the audible beeper.
:STATe	<boolean value>	Std	Enables/disables the beeper.
:VOLume	<numeric value>	Std	Sets the volume of the beeper. Range is 0 to 100, where 0 is off and 100 is maximum volume.
:COMMunicate		Std	Subsystem. Controls the RS232 and GPIB interfaces.
:GPIB		Std	Subsystem. Controls the physical configuration of the GPIB port.
:ADDRess	<numeric value>	Std	Sets the GPIB of the instrument.
:SERial		Std	Subsystem. Controls the physical configuration of the RS232 port.
:BAUD	4800 / 9600 / 19200 / 38400 / 57600 / 115200 /	Std	Sets the baud rate for both receiving and transmitting using the DB9 RS232 port.
:USB	4800 / 9600 / 19200 / 38400 / 57600 / 115200 /	New	Sets the baud rate for communication when using mapped comports for USB and Ethernet communication. Must be set to the default value (115200) for raw TCP/IP communication (i.e. Labview).
:ECHO	<boolean value>	New	Enables/Disables transmission of characters received on the DB9 serial port.
:KLOCK	<boolean value>	New	Locks the keypad.
:AUTorun	<boolean value>	New	After power-up, unit will start generating pulses automatically.
:VERSion?		Std	Query only. Returns SCPI version number in the form: YYYY.V ex. 1999.0
:SERN?		New	Query only. Returns the serial number.

Keyword	Parameter	Std/ New	Comments
:DISPlay		Std	Subsystem. Contains commands to control the display.
:MODE	<boolean value>	New	Enables/Disables automatic display update. When true, front panel display is updated with serial command parameter changes. Setting to false decreases response time.
:UPDate?		New	Query only. Forces update of display. Use when mode is false.
:BRIGhtness	<numeric value>	New	Controls intensity of display. Range is 0 to 4, where 0 is off and 4 is full intensity.

IEEE 488.2 Common Commands

Mnemonic	Command Name	Parameters	Comments
*IDN?	Identification Query		Queries the Pulse Generator Identification. The ID will be in the following format: model#-#channels-option#-version#
*RCL	Recall Command	<numeric value>	Restores the state of the Pulse Generator from a copy stored in local nonvolatile memory (0 through 12 are valid memory blocks).
*RST	Reset Command		Resets the Pulse Generator to the default state.
*SAV	Save Command	<numeric value>	Stores the current state of the Pulse Generator in local nonvolatile memory (1 through 12 are valid memory blocks).
*TRG	Trigger		Generates a software trigger pulse. Operation is the same as receiving an external trigger pulse.
*LBL	Setup Label	<string value>	Query Form returns the label of the last saved or recalled configuration. Command Form sets the label string for the next "*sav" command. String must be in double quotes, 14 characters max.

Appendix

Appendix A - Specifications

575 Specifications

Pulse Generation

RANGE	
DELAY	0 - 1000s
WIDTH	10ns - 1000s
RESOLUTION	250ps
TIMEBASE	50MHz
TIMEBASE ACCURACY	25PPM
RMS JITTER	400ps
PULSE INHIBIT DELAY	250ns
OUTPUT INHIBIT DELAY	250ns

INTERNAL RATE GENERATOR

RATE	0.0002Hz to 20.000MHz
RESOLUTION	5ns
ACCURACY	Same as timebase
JITTER	200ps
SETTLING	1 cycle
BURST MODE	1 to 10,000,000

TTL/ADJUSTABLE OUTPUTS

NUMBER	2, 4 or 8 Channel Outputs
LOAD	50 ohm
RISE TIME	3ns typ TTL 15ns typ @ 20V (high imp) Adj 25ns typ @ 10V (50 ohms) Adj
SLEW RATE	>0.5 V/ns TTL >0.1V/ns Adj
OVERSHOOT LEVELS	<100mV + 10% of pulse amplitude TTL 0 to 4 VDC VAR adjustable amplitude, 2.0 to 12.0 VDC with 10mV res, 12.0 VDC max transition
ACCURACY	1ns + .001 x Delay

EXTERNAL INPUTS

TRIGGER INPUTS

NUMBER	0, 2 or 4
RATE	DC to 1/ (0.2us + longest delay)
THRESHOLD	0.2 to 15VDC
MAXIMUM INPUT VOLT.	60V Peak
RESOLUTION	10mV
IMPEDANCE	1000 ohm
SLOPE	Rising or Falling
IMPEDANCE	1000 ohm
JITTER	800ps RMS
INSERTION DELAY	160ns
MINIMUM PULSE WIDTH	2ns

GATE INPUTS

THRESHOLD	0.2 to 15 VDC
MAXIMUM INPUT VOLT.	60V Peak
RESOLUTION	10mV
POLARITY	Active High/Active Low
FUNCTION	Pulse Inhibit or Output Inhibit
CHANNEL BEHAVIOR	Global w/ Individual Channel
PULSE INHIBIT DELAY	120ns
OUTPUT INHIBIT DELAY	45ns

OPTICAL OUTPUTS

NUMBER	2, 4 or 8
WAVELENGTH	820nm or 1300nm
MAXIMUM SIGNAL RATE	5MBd
MAXIMUM LINK DIST.	1.5km
CONNECTOR TYPE	ST
RESOLUTION	500ps
ACCURACY	1ns + .001 x Delay

OPTICAL INPUTS

NUMBER	0, 2 or 4
WAVELENGTH	820nm or 1300nm
MAXIMUM SIGNAL RATE	5MBd
MAXIMUM LINK DIST.	1.5km
CONNECTOR TYPE	ST
RESOLUTION	500ps
ACCURACY	2ns + .001 x Delay
OPTICAL TRIGGER	2412
TRIGGER DELAY	<300ns
JITTER	<15ns

STANDARD FEATURES/FUNCTIONS

COMMUNICATIONS	USB/RS232
GLOBAL GATES/TRIGGERS	2 Global Gate/Trigger Inputs
CHANNEL GATES/TRIGGERS	Optical/Electrical Available (5ns Jitter)
EXTERNAL CLOCK IN	10MHz - 100MHz User selectable in discrete values
EXTERNAL CLOCK OUT	V in - 3V min 10MHz - 100MHz User selectable in discrete values
COMMAND SET COMPATIBILITY	Backwards Compatible

OPTIONS

- I - Incrementing
- COM - Extended Communications (Ethernet, GPIB)

MODULES

- Standard Dual TTL/Adjustable
- Dual High Voltage
- Dual Optical
- Dual Standard Input Module
- Dual Optical Input Module







Appendix B - Safety Symbols

Safety Marking Symbols

Technical specifications including electrical ratings and weight are included within the manual. See the Table of Contents to locate the specifications and other product information. The following classifications are standard across all QC products:

- Indoor use only
- Ordinary Protection: This product is NOT protected against the harmful ingress of moisture.
- Class 1 Equipment (grounded type)
- Main supply voltage fluctuations are not to exceed +10% of the nominal supply voltage.
- Pollution Degree 2
- Installation (overvoltage) Category II for transient overvoltages
- Maximum Relative Humidity: <80% RH, non-condensing
- Operating temperature range of 0° C to 40° C
- Storage and transportation temperature of -40° C to 70°
- Maximum altitude: 3000 m (9843 ft.)
- This equipment is suitable for continuous operation.

This section provides a description of the safety marking symbols that appear on the instrument. These symbols provide information about potentially dangerous situations which can result in death, injury, or damage to the instrument and other components.

Symbols	Publications; Descriptions & Comments
	IEC 417, No. 5031 Direct current - Vdc may be used on rating labels.
	IEC 417, No. 5032 Alternating current - For rating labels, the symbol is typically replaced by V and Hz as in 230V, 50Hz. DO NOT USE Vac.
	IEC 417, No. 5033 Both direct and alternating current
	IEC 617-2 No. 02-02-06 Three-phase alternating current
	IEC 417, No. 5017 Earth (ground) terminal - Primarily used for functional earth terminals which are generally associated with test and measurement circuits. These terminals are not for safety earthing purposes but provide an earth reference point.
	IEC 417, No. 5019 Protective conductor terminal - This symbol is specifically reserved for the protective conductor terminal and no other. It is placed at the equipment earthing point and is mandatory for all grounded equipment
	IEC 417, No. 5020 Frame or chassis terminal - Used for points other than protective conductor and functional earth terminals where there is a connection to accessible conductive terminals to advise the user of a chassis connection.



IEC 417, No. 5021

Equipotentiality - Used in applications where it is important to indicate to the operator that two or more accessible functional earth terminals or points are equipotential - More for functional rather than for safety purposes



IEC 417, No. 5007

On (Supply) - Note that this symbol is a bar, normally applied in the vertical orientation. It is not the number 1.



IEC 417, No. 5008

Off (Supply) - Note that this symbol is a true circle. It is not the number 0 or the letter O.



IEC 417, No. 5172

Equipment protected by double insulation or reinforced insulation (equivalent to Class II if IEC 60536)



ISO 3864, No. B.3.6 Background colour - yellow; symbol and outline – black

Caution, risk of electric shock - Generally used only for voltages in excess of 1000 V. It is permissible to use it to indicate lower voltages if an explanation is provided in the manual. Colour requirements do not apply to markings on equipment if the symbol is moulded or engraved to a depth or raised height of 0.5 mm, or that the symbol and outline are contrasting in colour with the background.



IEC 417, No. 5041 Background colour - yellow; symbol and outline – black

Caution, hot surface - Colour requirements do not apply to markings on equipment if the symbol is moulded or engraved to a depth or raised height of 0.5 mm, or that the symbol and outline are contrasting in colour with the background.



ISO 3864, No. B.3.1 Background colour - yellow; symbol and outline – black

Caution - (refer to accompanying documents) used to direct the user to the instruction manual where it is necessary to follow certain specified instructions where safety is involved. Colour requirements do not apply to markings on equipment if the symbol is moulded or engraved to a depth or raised height of 0.5 mm, or that the symbol and outline are contrasting in colour with the background.



IEC 417, No. 5268-a
In-position of bistable push control



IEC 417, No. 5269-a
Out-position of bistable push control

Appendix C - 35V Output Module

AT35V Output Module

When the Adjustable Mode is enabled for this module, the outputs will provide an adjustable output from 5 volts to 35 volts. The pulse width can be set over the standard range of the unit, but the 35 volt output will self limit to approximately 4 μ s with some droop. To maintain the highest possible rise time, care must be taken with cabling and termination. Low capacitance cable and 50 ohm termination will provide the fastest rise times without overshoot. Faster rise times can be achieved by increasing the termination resistance, but some overshoot is likely to occur.

35V Specifications

Output	5V - 35V
Setpoint Resolution	10mV
Rise Time	< 30ns
Accuracy	500mV @ 400Hz
Max. Frequency (Internal & External)	1000Hz

Appendix D - Dual Trigger Input

DT15 Dual Trigger Module

This module option This module option allows the Gate input to double as a second trigger input. For consistency, the enabling menu for this option is located under the 'Trigger' menu structure. Once you have enabled the trigger functionality of the unit, both the 'Gate' input and the 'Trig' input can act as trigger inputs. However, in this case the 'Gate' input can still act as a system or channel gating signal as well as a trigger signal.

If your unit has this option, the 'Trigger' button will have two menus, one for adjusting the "Level" and "Edge" for "T" and another for adjusting "G". The "T" designates the "Trig" input and the "G" designates the "Gate" input. The "Level" for the 'Gate' input can also be adjusted from the 'Gate' menu.

Once you have enabled the triggering functionality of the unit, you can then choose which channels will be triggered off of the 'Gate' input and which channels will be triggered off of the 'Trig' input. This selection can be done in the secondary channel menus which are accessed by first pushing the yellow 'Func' button, then pushing the button of the channel of interest. The option is labeled "Trig Src:"; indicating the trigger source.

Also note that there is another secondary channel menu that allows you to choose whether or not that particular channel is gated off of the 'Gate' input, while also allowing the option to trigger off of the 'Trig' input or 'Gate' input.

575 SCPI Dual Trigger Command Summary

Keyword	Parameter	Std/ New	Comments
*TTG		New	Generates a software trigger pulse for the TRIG input only. Operation is the same as receiving an external trigger pulse.
*GTG		New	Generates a software trigger pulse for the GATE input only. Operation is the same as receiving an external trigger pulse.
:PULSe [1 / 2 n]		New	Subsystem. Contains commands to control the output pulse generation. Valid suffix range depends on the number of channels (ChA-1, ChB-B, etc...). Command without suffix refers to the currently selected logical instrument. See INSTRUMENTS subsystem.
:CTRigger	Trig Gate	New	Allows the selection of which input trigger to use.
:TRIGger		New	Subsystem. Contains commands to control the input trigger parameters.
:GEDGe	RISing or FALLing	New	Selects which edge the 'Gate' input triggers on
:PULSe [0]		New	Subsystem. Contains commands to control the output pulse generation. Commands without suffix refer to the currently selected logical instrument. See INSTRUMENTS subsystem.
:GATe		New	Subsystem. Contains commands for the 'Gate' input.
:Level	Numeric Value	New	Allows you to set the trigger level for the 'Gate' input.

Appendix E - Impedance Matching Outputs

TZ50 Impedance Matching Output Module

This module option allows a user to have a 50 Ohm load on the output while maintaining an output amplitude of at least 4 Volts while in the TTL/CMOS mode. All other functionality of the module is the same as the AT20 modules, including output while using the AdjustableMode Function of the channels.

Appendix F - COM

Ethernet Interace Overview

An Ethernet interface is optional on the 575. When this option is chosen, the USB port is replaced by the Ethernet port.

The Ethernet module used is a “Digi Connect ME” module supplied by Digi Connectware, Inc. There are several ways to successfully communicate with the pulse generator over Ethernet. The two most popular methods are raw TCP/IP (such as Labview or programming with VISA libraries) and by mapping a pc COM port using the Digi Connectware’s “Realport Drivers”.

Whatever method of Ethernet communication is ultimately desired, the utilities supplied by Digi Connectware (included on the cd shipped with the Ethernet-option pulse Generator) will be critical to implementing the communications. Please install the following utilities:

Ethernet Communication Notes:

- The Digi Connectware’s “Digi Device Discovery” can be used to determine what IP address was assigned by the local DHCP server (if any).
- “Digi Device Discovery” can also be used to open a web interface to the Ethernet module. Simply double-click on the IP address that is displayed in the Digi Device Discovery utility.

Username: “root”
Password: “dbps”

- If a mapped COM port is the desired communication method, the Digi Connectware’s “Realport Drivers” setup must be used to install the COM port on the pc. The virtual COM port is then local to the computer it was installed on. Please refer to the Digi Connectware Documentation supplied on the CD, or call Berkeley Nucleonics Technical Support.
- The pulse generator’s SCPI parameter “.SYSTEM:COMMunicate:SERial:USB n” is defaulted to 115200 and should not be changed for Ethernet communication, whether or not a mapped COM port is used. The virtual COM port on the pc should be set to 115200 BAUD.
- Echo functionality is not available on the Ethernet port.

Programming Command Types and Format

The 575 pulse generator uses two types of programming commands: IEEE 488.2 Common Commands and Standard Commands for Programmable Instruments (SCPI). The format is the same for all interfaces. Hyperterminal (in Windows) or any other generic terminal program may be used to interactively test the commands using the RS232 interface.

Appendix G - Ethernet Connectivity

IP Address and Raw TCP/IP Connection

This document describes one of the most popular methods of setting up Ethernet communication for the Berkeley Nucleonics pulse generators. The method discussed is Raw TCP/IP communication.

The Ethernet module used in Quantum Composers pulse generators is a “Digi Connect ME” device manufactured by Digi International, Inc. It supports virtually all practical Ethernet communication methods. A set of utilities and documentation by Digi is included on the CD shipped with the pulse generator.

This discussion assumes that the Digi utilities included with your pulse generator and National Instruments VISA (version 3.3 in this procedure, see National Instruments’ website) are installed. The procedures discussed have been prepared using Windows XP service pack 2.

Determining IP Address

The Digi module has been reset to factory defaults before it left the manufacturing facility. In this mode, it is ready to be assigned an IP address by the local DHCP server. If a crossover cable is being used, the Ethernet device will assume a default IP address.

The Digi utility “Digi Device Discovery” can be used to determine the IP address that is currently assigned to the Ethernet module. Hit “Start, All Programs, Digi Connect, Digi Device Discovery”. When the utility opens, it scans the LAN looking for Digi Ethernet modules. It may take a minute after plugging in or powering the Ethernet module before the LAN negotiates the connection with the Digi module. Hit “Refresh View” in the left column after a minute or so if the utility fails to see the unit when you start it. In some situations it is possible that the Windows Firewall will block the Digi Device Discovery from being able to see the unit. It is advisable to turn the Windows Firewall off while performing these tasks. When the utility sees the Digi device, it will display it in the list (Figure 1).

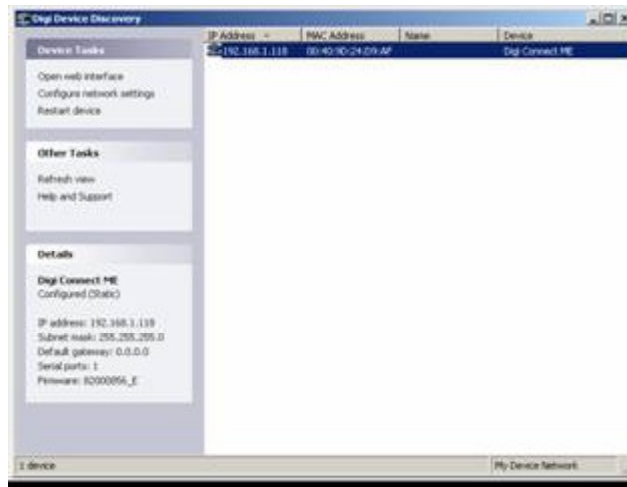

Figure 1: Digi Device Discovery utility displaying Digi module discovered on the LAN.

From this point, a web interface can be opened, allowing access to configuration options for the Digi module. If you are required to enter a username and password, they are as follows:

- Username: "root"
- Password: "dbps"

If a static IP address is desired, this change can be made from the web interface. Please note, however, that if the IP address is changed such that it is incompatible with the LAN, all communication including access to the module's settings (including the IP address!) will no longer be possible over the LAN. If this happens, a crossover cable must be used to access the Digi module's settings (again using Digi Device Discovery). Temporarily set the pc's IP address to be compatible with the Digi module's IP address to get the pc and pulse generator to 'see' each other over the crossover cable.

This document was created with Win2PDF available at <http://www.daneprairie.com>.
The unregistered version of Win2PDF is for evaluation or non-commercial use only.